

rullari®



VERTICAL ROLLER SHUTTER CURTAIN ME 30 U | ME 30 R | ME 30 S



ME 30 U ME 30 R | ME 30 S

Aluminum Rullari vertical roller shutter curtains are designed and manufactured in Finland. The starting point for the design has been Scandinavian architecture. Kokema Oy has nearly 40 years' experience in the manufacture of roller curtains. The lightweight and durable material creates a high quality, stylish design without compromising the ease of use of the vertical roller shutter curtains. Rullari vertical roller shutter curtains are CE certified (EN13241).

Vertical roller shutter curtains are reliable and safe to use. They are suitable for both indoor and outdoor use. Vertical roller shutter curtains are manufactured according to the customer's specifications and professional installation service all over Finland manages the installation of the gates flexibly. Uses include serving lines, customer service points, restaurants, kiosks, etc...

SLAT CURTAIN

The slat curtain of vertical roller shutter curtain consists of a 30 mm wide extruded aluminium profile, and the profile ends are locked together by means of screws. The ME 30 U slat is closed and the ME 30 R slat is perforated either with rectangle holes or oval holes. The maximum size of the vertical roller shutter curtain is 7000 x 1500 mm. The weight of the vertical roller shutter curtain is approx. 6 kg/m².

GUIDE RAILS, FIXING ANGLES, ROLLER BARREL

The vertical roller shutter curtain runs on upper and lower guide rails (18 x 22 mm), which are also extruded aluminium. In a vertical roller shutter curtain, the curtain rolls to the side of the mounting hole on a separate aluminum shaft.

OPERATION

Rullari vertical roller shutter curtains are always hand-operated. There is a spring inside the roller barrel to ensure that the slat curtain rolls on the axle. The vertical roller shutter curtain has a pull slat, from which the curtain is pulled to the closed position and pushed into the open position.

LOCKING

The Rullari vertical roller shutter curtains are equipped with an espagnolette bolt.

SURFACE TREATMENT

The vertical roller shutter curtains are delivered with standard natural color anodising. The curtains can also be powder coated with RAL Classic colour tone or colour anodised.

KOKEMA_{OY}

Kakkulaistentie 5, 32800 Kokemäki
Tel. +358 10 326 3840
info@kokema.fi | www.kokema.fi

STRUCTURE

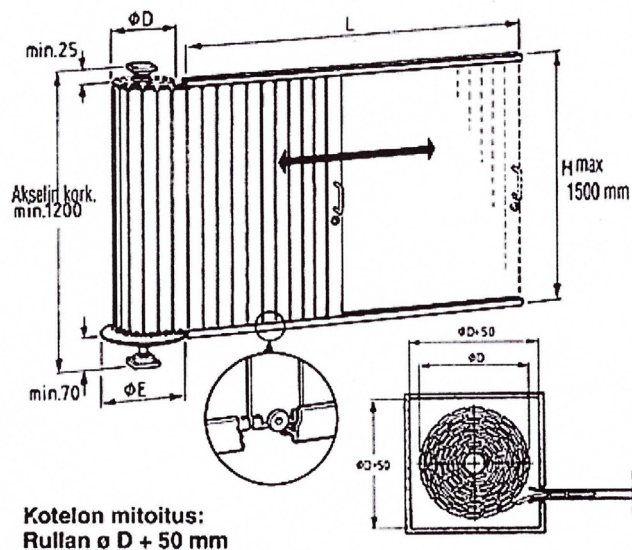

ME 30 R

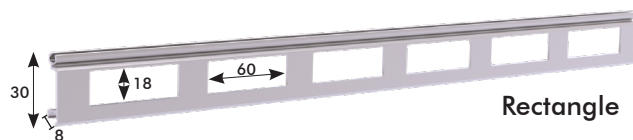
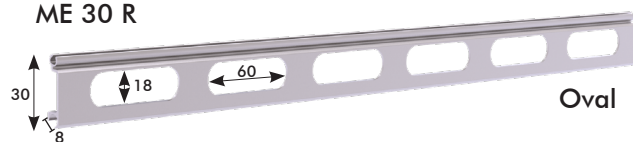

ME 30 U

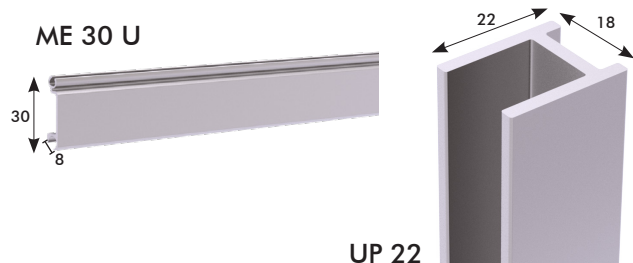

HORIZONTAL DIMENSIONING

The width of the opening

The space required by the roll

2000 mm	200 mm
2500 mm	210 mm
3000 mm	220 mm
3500 mm	230 mm
4000 mm	240 mm
4500 mm	260 mm
5000 mm	270 mm
5500 mm	290 mm
6000 mm	310 mm
6500 mm	330 mm
7000 mm	350 mm