

rullari®

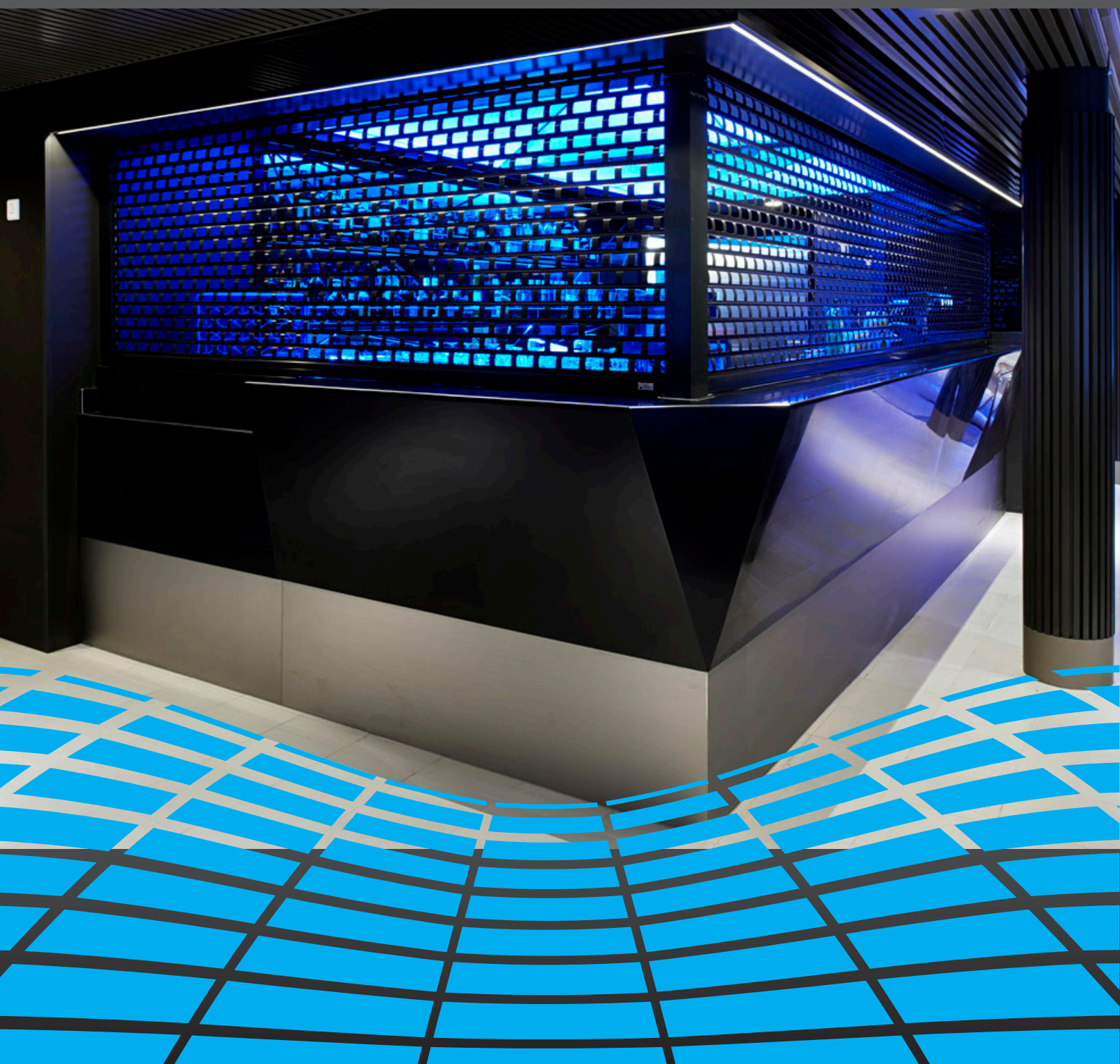

ROLLER SHUTTER CURTAIN CD 600 R & CD 600 K



CD 600 R & CD 600 K

Aluminum Rullari roller shutter curtains are designed and manufactured in Finland. The starting point for the design has been Scandinavian architecture. Kokema Oy has almost 40 years' experience in roller shutter curtain manufacturing. The lightweight and durable material creates a high-quality and stylish package, without forgetting the ease of use. The Rullari roller shutter curtains are **CE** compliant (EN13241). Rullari roller shutter curtains are suitable for both indoor and outdoor use. The curtains are made to the customer's specifications and highly professional installation services are available all over Finland for flexible installation. Uses include serving lines, customer service points, restaurants, kiosks, etc...

SLAT CURTAIN

The slat curtain of the Rullari roller shutter curtain consists of a 50 mm wide extruded aluminium profile, and the profile ends are locked together by means of screws. The slat is perforated and the hole size is 60 x 32 mm. The maximum size of the roller shutter curtain is 7900 x 4500 mm. The weight of the curtain is approx. 6 kg/m².

GUIDE RAILS, FIXING ANGLES AND ROLLER BARREL

Aluminium guide rails on the sides of the curtain (80 x 34 mm) are also made of extruded aluminium. Guide rails are equipped with PVC slide belts. The gloss galvanized fixing angles for the roller barrel are already installed on the guide rails. The roller barrel is made of galvanized or painted steel. There is a tubular motor inside the roller barrel.

OPERATION

Rullari roller shutter curtains are electrically operated and force controlled. The standard motor used in the curtains is a single-phase tubular motor. Curtains are controlled via pushbuttons or a lockable key switch. Manually operated small curtains (under 3000 x 1500 mm) can also be manufactured.

LOCKING

The curtains are equipped with automatic locks. Hand-operated curtains can be equipped with lever bolt locks or Abloy furnishing locks.

SURFACE TREATMENT

The roller shutter curtains are delivered with standard natural color anodising. The curtains can also be powder coated with RAL Classic colour tone or colour anodised.

ADDITIONAL OPTIONS

- Emergency operation (manual opening of the motor in case of power failure)
- Pural-coated metal casing (max. curtain size in casing: 3000 x 1500 mm)
- The aluminium protective case, powder coated RAL Classic tone

KOKEMA_{OY}

Kakkulaistentie 5, 32800 Kokemäki
Tel. +358 10 326 3840
info@kokema.fi | www.kokema.fi

STRUCTURE

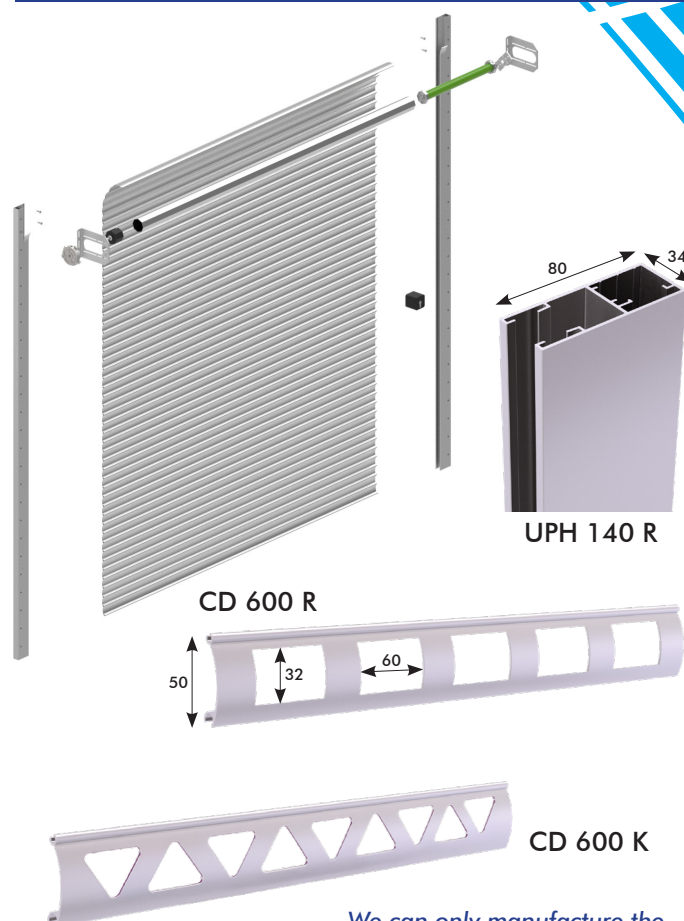

We can only manufacture the CD 600 K in widths up to 3 m.

INSTALLATION OPTIONS

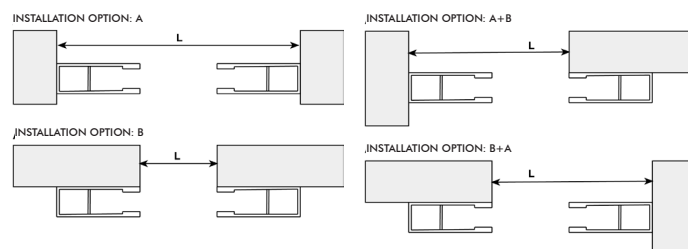

VERTICAL DIMENSIONING

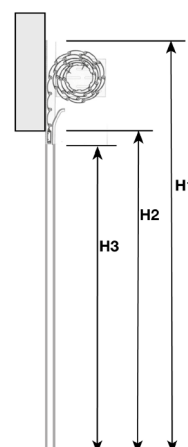

Height of the opening (H2): The space required by the roll (H1-H2):

1000 mm	180 mm
1500 mm	200 mm
2000 mm	220 mm